

This document provides guidelines for the mounting of video or still cameras to an automobile.

Guidelines

Where a camera or lens unit fitted to an automobile exceeds a weight of 1 kg, it is strongly recommended that the mounting of the video camera or lens unit be carried out in the following manner:

- A cradle should be attached to the safety cage where present by means of a clamp style bracket secured by at least two 6mm class 8.8 bolts.
NOTE: Refer to Drawing 1 below for suggested cradle material specifications and design.
- Where no safety cage is present, the cradle should be securely mounted to a substantial section of interior bodywork.
- Where a remote style lens is used, the main unit should be mounted in a metal box, securely fixed in place (eg. 5mm thick alloy held in place by minimum 3 X 6mm class 8.8 bolts).
- The use of the ¼ Whitworth screw mount present on most cameras should not be used on its own.

NOTE FOR COMPETITORS: It is foreshadowed that from 1 January 2009, the maximum weight of any camera, lens or recording unit mounted to other than the floor shall be 100g.

Diagram 1

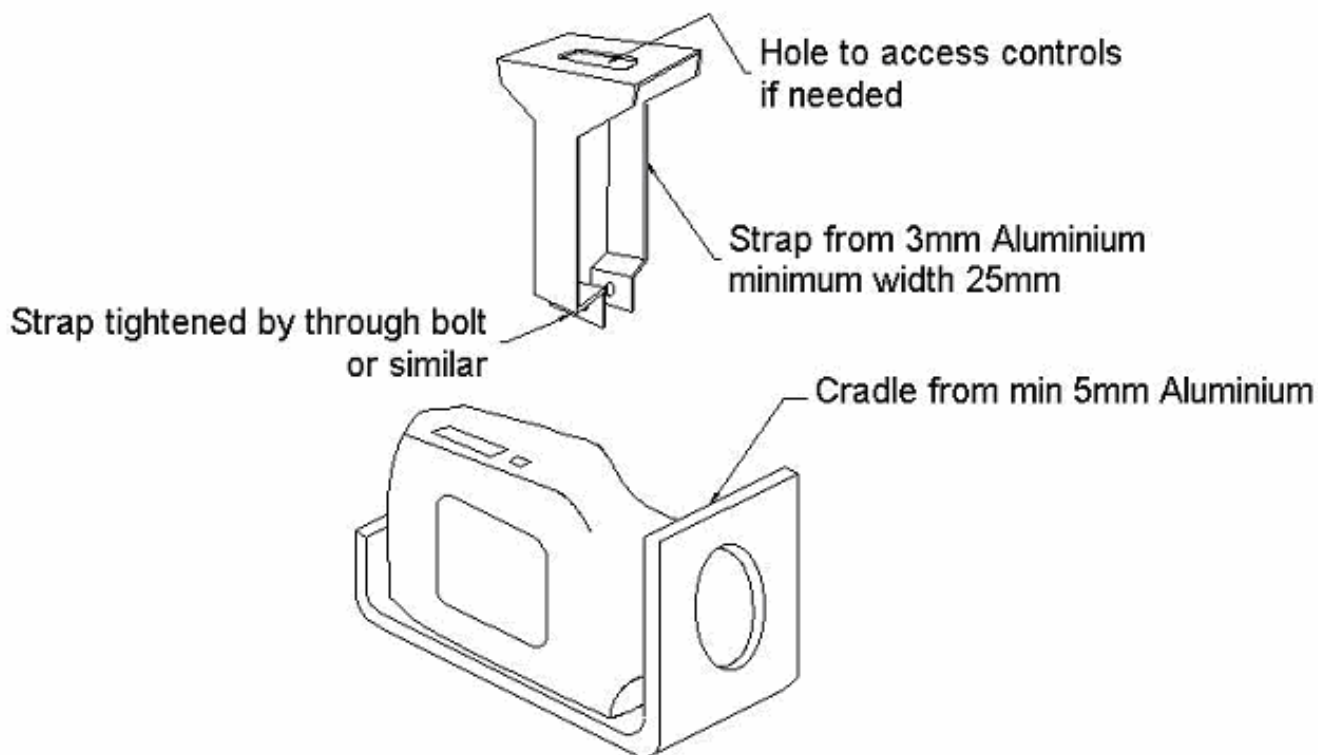

Confederation of Australian Motor Sport Ltd

A.B.N. 55 069 045 665

www.cams.com.au

851 Dandenong Road, Malvern East VIC 3145 PO Box 147, Caulfield East VIC 3145
Telephone: (03) 9593 7777 Facsimile: (03) 9593 7700

